

# FL 9BW

FL 9BW is a cooled CMOS camera designed for long exposure imaging. It not only incorporates high sensitivity and low noise advantages from latest sensor technologies, but also leverages Tucsen's many years experiences on cooling chamber design and advanced image processing. FL 9BW is able to capture clean and even images for up to 60 minutes exposure time.



Key Features	Benefits
Scientific Grade CMOS	92 % peak QE, 0.9 e <sup>-</sup> readout noise and no glow.
< 0.0005 e <sup>-</sup> /p/s Dark Current	Equivalent to the cooled CCD for long exposure imaging.
16000 : 1 Dynamic Range	More than 4 times that of the CCD, greatly expanding the signal detection range.
Pixel Correction Technology	High background quality ensures more accurate quantitative analysis. <sup>[1]</sup>
Flexible Binning Mode	Improving the sensitivity and dynamic range capability.
High Reliability Cooling Chamber	Cooled to -25 °C @ 22 °C, no condensation or other problems.
Compact Design	Conducive to instrument system integration.

## Typical Applications

- Chemiluminescence
- Bioluminescence
- PCR
- Fluorescence imaging

## Noted Examples

[1] The FL 9BW has excellent background uniformity, as it has basically eliminated the bad factors such as amplifier glow and bad pixels.

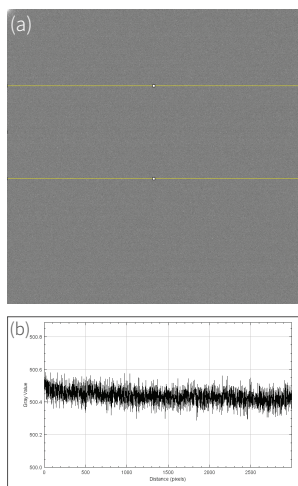
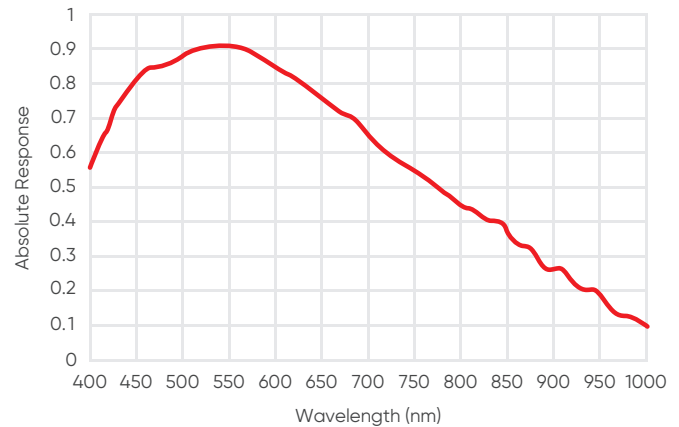
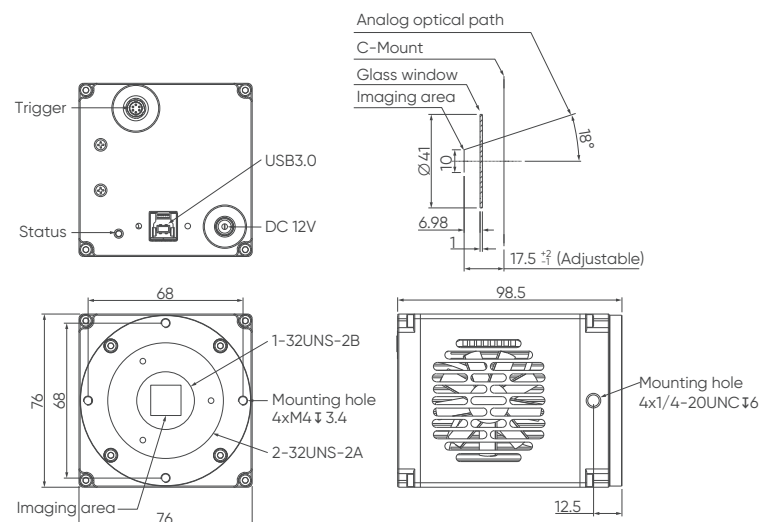

Figure (a) is the background image taken by FL 9BW with 600s exposure. Figure (b) is the grayscale intensity curve corresponding to the yellow region, showing excellent background uniformity.

## Quantum Efficiency



## Dimensions (Unit: mm)



**Technical Specifications**

Model	FL 9BW		
Sensor Type	BSI CMOS		
Sensor Model	SONY IMX533CLK-D		
Color/Mono	Mono		
Array Diagonal	15.96 mm (1")		
Effective area	11.28 mm × 11.28 mm		
Pixel Size	3.76 μm × 3.76 μm		
Resolution	3000 × 3000, 9 MP		
Peak QE	92% @ 530 nm		
Dark Current	< 0.0005 e-/p/s		
Bit Depth	14 bit @ bin1, Extended to 16 bit with FPGA binning		
Gain Mode	Gain 0 - High-Capacity	Gain 1 - Balanced	Gain 2 - Sensitive
Full well capacity	Gain0: 47 ke- @ bin1; > 180 ke- with binning	Gain1: 16 ke- @ bin1; > 64 ke- with binning	Gain2: 3 ke- @ bin1; > 12 ke- with binning
Readout Modes	Standard, Low-Noise		
Readout noise (Standard)	3.2 e- @ Gain0	1.2 e- @ Gain1	1.0 e- @ Gain2
Readout noise (Low-Noise)	2.5 e- @ Gain0	1.0 e- @ Gain1	0.9 e- @ Gain2
Frame Rate	18 fps @ Standard Mode, 12 fps @ Low Noise Mode		
Shutter Mode	Rolling		
Exposure Time	12.2 μs ~ 60 min		
Image Processing	DPC		
ROI	Supported		
Binning	2x2, 3x3, 4x4, 6x6, 8x8		
Cooling Method	Air		
Cooling Temperature	Cooled to -25 °C @ Ambient temperature (22 °C)		
Trigger Mode	Hardware, software		
Output Trigger Signals	Exposure start, Global, Readout end, High level, Low level		
Trigger Connector	Horise		
SDK	C, C++, C#		
Data Interface	USB 3.0		
Optical Interface	C-Mount, Customizable		
Power	12 V / 6 A		
Power Consumption	≤ 40 W		
Operating Environment	Temperature 0~40 °C, Humidity 10~85%		
Storage Environment	Temperature -10~60 °C, Humidity 0~85%		
Dimensions	76 mm x 76 mm x 98.5 mm		
Operating System	Windows / Linux		